



Tlfno: +34 94 475 07 11 – Fax: +34 94 447 11 06

MOLSA – TALLERES MOL, S.L – POL. ASUA-BERRI PAB. 19-20 – 48950 ASUA-ERANDIO

COMPANY
CONTACT
ADDRESS
PHONE/FAX
E-MAIL

### SLIP RINGS DESCRIPTION

(dimensions in millimetres or inches)

Date:

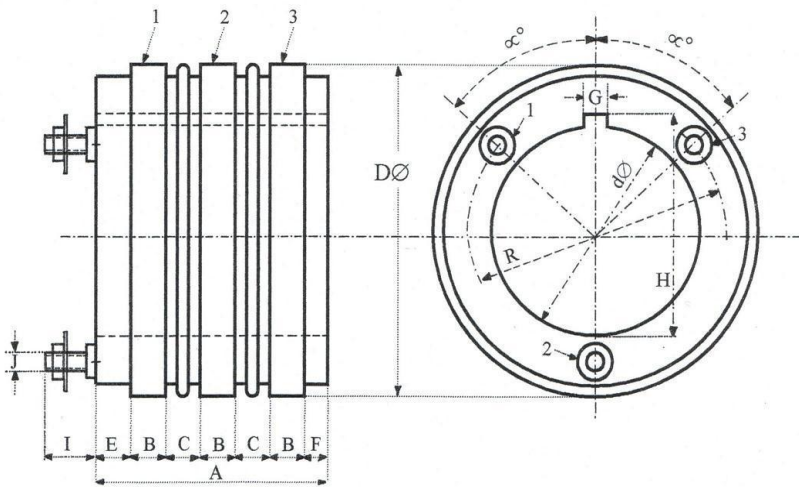

QUANTITY

Nº RINGS

A	Total length without connectors	
B	Rings width	
C	Separation between rings	
E	Front	
F	Rear	
G	Keyway	
J	Type of connectors	

DØ	Outside diameter	
dØ	Inside diameter	
H	Inside diameter + keyway	
I	Connectors length	
R	Connectors diameter	
α°	Separation between connectors	

Threaded rod  Flat bar  Cable

Voltage (V)
Power (CV / KW)
Amperage (A)
Working temperature (°C)
Operating speed (RPM)

COMMENTS